



Total Access Rackmount 6-Amp Power Supply Battery Charger Installation and Maintenance Practice

Document Number: 61180043L2-5D

CLEI: VAPUKT0C__

June 2005

Trademarks

Any brand names and product names included in this manual are trademarks, registered trademarks, or trade names of their respective holders.

To the Holder of the Manual

The contents of this publication are current as of the date of publication. ADTRAN® reserves the right to change the contents without prior notice.

In no event will ADTRAN be liable for any special, incidental, or consequential damages or for commercial losses even if ADTRAN has been advised thereof as a result of issue of this publication.



901 Explorer Boulevard
P.O. Box 140000
Huntsville, AL 35814-4000
(256) 963-8000

©2005 ADTRAN, Inc.
All Rights Reserved.
Printed in U.S.A.

Revision History

Revision	Date	Description
D	June 2005	Updated to remove Dual PS/BC Jumper Cable. Document format updated with revision D.

Conventions

The following typographical conventions are used in this document:

[This font](#) indicates a cross-reference link. First-time references to tables and figures are shown in **this font**.

This font indicates screen menus, fields, and parameters.

THIS FONT indicates keyboard keys (ENTER, ESC, ALT). Keys that are to be pressed simultaneously are shown with a plus sign (ALT+X indicates that the ALT key and X key should be pressed at the same time).

This font indicates references to other documentation and is also used for emphasis.

This font indicates on-screen messages and prompts.

This font indicates text to be typed exactly as shown.

This font indicates silkscreen labels or other system label items.

This font is used for strong emphasis.

NOTE

Notes inform the user of additional but essential information or features.

CAUTION

Cautions inform the user of potential damage, malfunction, or disruption to equipment, software, or environment.

WARNING

Warnings inform the user of potential bodily pain, injury, or death.

Training

ADTRAN offers training courses on our products. These courses include overviews on product features and functions while covering applications of ADTRAN's product lines. ADTRAN provides a variety of training options, including customized training and courses taught at our facilities or at customer sites. For more information about training, please contact us.

Training Phone: 800-615-1176, ext. 7500

Training Fax: 256-963-6700

Training Email: training@adtran.com

Contents

General	1
Features	1
Document Review	2
Description	2
Single or Dual Battery	2
PS/BC Mounting Location	2
Battery Disconnect Protection Circuit	3
DC Over Voltage Protection	3
Alarm Relays	3
Fuse	3
LED Indication	4
Compliance	4
Installation	5
Shipping Contents	5
Mounting the PS/BC	6
Alternate Mounting	7
Provisioning	7
Wiring Descriptions	7
Ground	7
120 VAC Power Input	7
DC Power Output	8
PS/BC to Battery Configurations	8
Battery Charge/Discharge	9
Alarm Wiring	9
Operation	9
Maintenance	9
Fuse	9
Specifications	10
Appendix A	
Warranty	A-1
Warranty and Customer Service	A-1
ADTRAN Sales	A-1
ADTRAN Technical Support	A-1
ADTRAN Repair/CAPS	A-1
Repair and Return Address	A-1

Figures

Figure 1.	Total Access PS/BC	1
Figure 2.	PS/BC Mounted On Battery Pack	6
Figure 3.	Wiring Block Diagrams	8

Tables

Table 1.	LED Descriptions	4
Table 2.	Power Factor and Efficiency	10
Table 3.	PS/BC Specifications	10

Total Access Rackmount 6-Amp Power Supply Battery Charger

GENERAL

This practice is an installation and maintenance guide for the ADTRAN® Total Access® Rackmount 6-Amp Power Supply Battery Charger (PS/BC). **Figure 1** illustrates the PS/BC (P/N 1180043L2) right and left side panels.

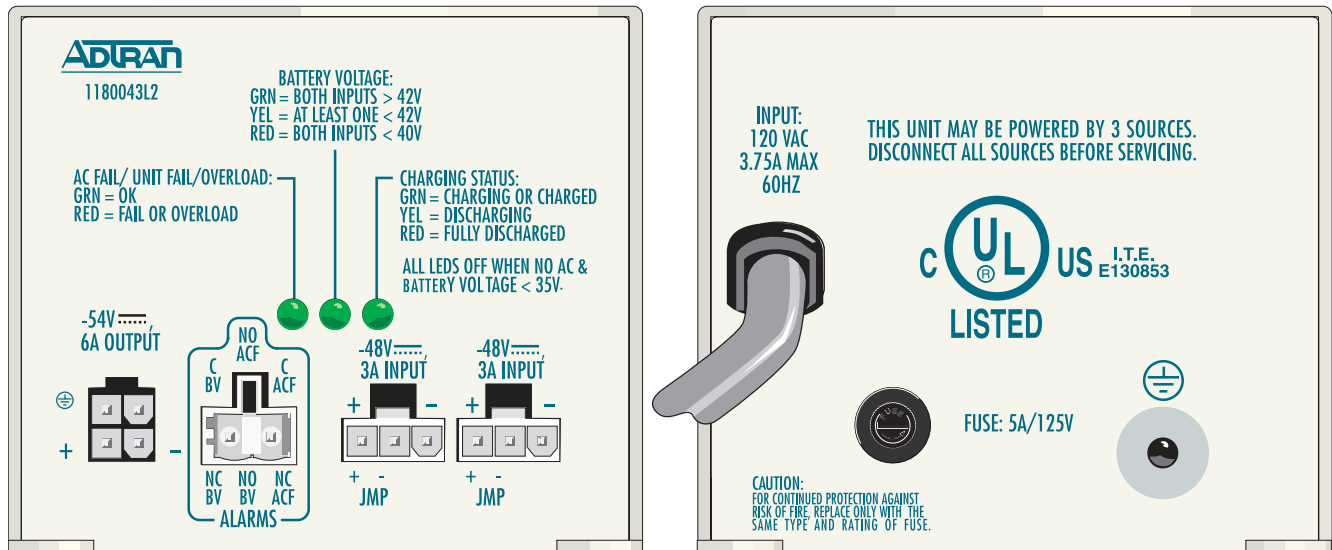

Figure 1. Total Access PS/BC

Features

The Total Access PS/BC features include the following:

- -54 VDC at 6-amps output for multiple use
- Modular connections for two backup battery packs
- Modular power output connection
- LED status for VAC, VDC, and battery charging
- Full battery recharge in less than eight hours
- Two PS/BC configuration options available

- Fuse protection
- Positive ground
- Battery Pack mounting hardware included
- Completely automatic operation
- Multiple protection features
- Uninterrupted power output if backup battery connected
- Meets NEBS Level 3 (all requirements of GR-63-CORE and GR-1089-CORE)
- FCC and UL 60950 compliant

Document Review

This document contains important pre-installation information. Craft personnel should review the entire document as part of installation planning.

DESCRIPTION

The PS/BC rectifier is part of the Total Access Rackmount AC Power Supply/Backup Battery System (APS/BBS). The unit is designed to work in conjunction with one or two ADTRAN backup battery packs (P/N 1175044L1).

Originally designed for the Total Access 1500 system, the PS/BC can be used in any application using 120 VAC input, and requiring up to -54 VDC, 6-amps output.

In the Total Access 1500 configuration, the rectifier performs AC to DC conversion and when used with the dual battery provides up to eight hours of backup power for a fully populated Total Access 1500 bank (96 FXS circuits) with up to 50 percent off-hook circuits at any one time.

For general use, the rectifier receives AC power from a standard 120 VAC wall outlet and converts this to -54 VDC, 6-amp output to the designated load plus recharging the single or dual battery, or maintaining battery at peak charge. Each battery has four series connected 12 volt rechargeable cells.

Single or Dual Battery

Each battery string is rated for 3 amps of current and 7 amp-hours of capacity. Dual batteries are required if the load exceeds these ratings during AC power failure (backup battery mode).

PS/BC Mounting Location

The PS/BC normally mounts to the associated battery pack. The unit can also mount to a special bracket within a cabinet, or mount external to a cabinet against a wall.

Battery Disconnect Protection Circuit

During battery operation a protection circuit disconnects battery from the main output when battery voltage drops below 39 VDC, preventing over discharge. When AC returns, the main output provides regulated -54 VDC, batteries recharge, and the system returns to normal. Refer to “[LED Indication](#)”.

After the protection circuit initiates, the LEDs remain on (red), continuing to slowly drain the battery. When battery voltage drops to 35 VDC, all load is removed from the battery. If AC power will not be available for an extended period (several days), disconnect the battery to prevent unnecessary discharge.

DC Over Voltage Protection

The PS/BC has a protection circuit that disables the rectifier to protect the load from a high output voltage caused by rectifier failure. The backup battery or redundant PS/BC supports the load in this instance. The over voltage event can permanently disable the PS/BC. Confirm this by performing the following procedure:

1. Disconnect the PS/BC from the AC source.
2. Wait 30 minutes minimum.
3. After 30 minutes plug back into the AC source.
4. If the unit has recovered, the **AC FAIL/UNIT FAIL/OVERLOAD** LED will turn on green and the unit returns to service. If the LED does not turn on green, replace the PS/BC.

Alarm Relays

There are two uncommitted alarm relays associated with PS/BC operation:

- AC Fail (ACF): Alarms if AC fails, the rectifier overloads, or the rectifier fails
- Battery Low Voltage (BV): Alarms if either or both battery voltage drops below 42 VDC

Fuse

A standard 5×20 mm 5-amp fuse adjacent to the AC power cord protects AC power feed overload in case of rectifier failure.

LED Indication

A set of three PS/BC multi color LEDs provide status for AC, DC, and battery charge conditions. See **Table 1** for LED descriptions. Descriptions are also labeled on the PS/BC.

Table 1. LED Descriptions

LED	Color	Description
AC FAIL/UNIT FAIL/OVERLOAD	Green	Normal 120 VAC operation
	Red	AC fail or rectifier overload or fail
BATTERY VOLTAGE	Green	Battery 1 and Battery 2 greater than 42 VDC
	Yellow	Battery 1 or Battery 2 less than 42 VDC
	Red	Battery 1 and Battery 2 less than 40 VDC
CHARGING STATUS	Green	Battery 1 and Battery 2 charged or recharging
	Yellow	Battery 1 or Battery 2 discharging
	Red	Battery 1 and Battery 2 fully discharged
All LEDs	Off	AC lost, Battery less than 35 VDC

Note: Descriptions are the same for a single battery.

Compliance

This device complies with Part 15 of the FCC rules. Operation is subject to the following two conditions:

1. This device may not cause harmful interference.
2. This device must accept any interference received, including interference that may cause undesired operation.

Changes or modifications not expressly approved by ADTRAN could void the user's authority to operate this equipment.

INSTALLATION



After unpacking the Total Access PS/BC, inspect it for damage. If damage has occurred, file a claim with the carrier, then contact ADTRAN Customer Service. Refer to “[Appendix A, Warranty](#)” for further information. If possible, keep the original shipping container for returning the PS/BC for repair or for verification of shipping damage.

CAUTION

Electronic modules can be damaged by ESD. When handling modules, wear an antistatic discharge wrist strap to prevent damage to electronic components. Place modules in antistatic packing material when transporting or storing. When working on modules, always place them on an approved antistatic mat that is electrically grounded.

Shipping Contents

The contents include the following items:

- Rackmount 6-Amp Power Supply Battery Charger
- Rackmount 6-Amp Power Supply Battery Charger *Installation and Maintenance Practice*
- Appropriate wiring:
 - PS/BC to AC source (hardwired)
 - PS/BC to load
 - PS/BC alarm output
- Battery Pack mounting hardware

Separately purchased Rack Mounting Kits for the PS/BC are available for the following racks:

- 19-inch (P/N 1175050L1)
- 23-inch (P/N 1175051L1)

Mounting the PS/BC

The PS/BC housing occupies a nominal area 15.35 inches (with mounting tabs) wide by 3.45 inches high and is designed so the four mounting tab screw holes align to threaded screw holes on the ADTRAN battery pack housing. This procedure assumes that the battery pack is mounted in the designated 19-inch or 23-inch rack. Hardware for mounting the PS/BC to the battery pack is included. To mount the PS/BC, perform the following steps:

1. Ensure a 120 VAC wall outlet is within reach of the PS/BC 10-foot power cord.
2. Determine the most convenient direction to view the status LEDs and position the PS/BC accordingly.
3. Align the mounting tabs to the threaded mounting holes on the battery pack.
4. Using the included “sems” screws with star washer, mount the PS/BC to the battery pack. Tighten fasteners firmly.

See [Figure 2](#) for a representative example of the PS/BC mounted to the battery.

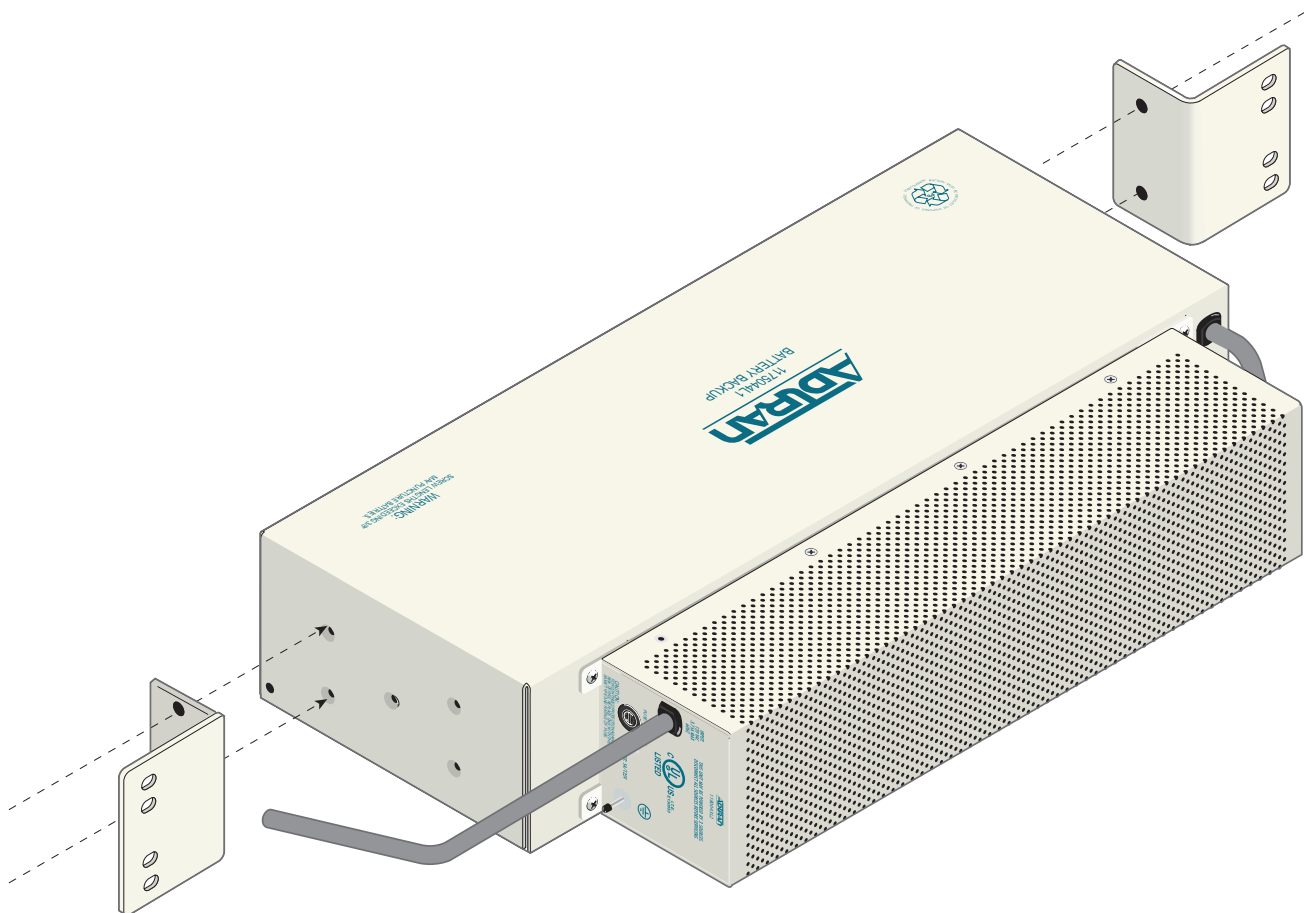

Figure 2. PS/BC Mounted On Battery Pack

Alternate Mounting

Two alternate mounting methods include mounting directly to a wall using customer supplied wood screws, or to a 16-gauge steel bracket (P/N 3265555) that mounts in the cabinet. Bracket mount location is normally at the battery position when batteries are mounted external to the cabinet. The bracket has threaded mounting holes that align to the PS/BC mounting tabs. The PS/BC can be mounted to either side of the bracket, or two PS/BCs can be mounted, one on each side. Openings in the bracket allow for wire management. Hardware for bracket mounting is purchased from ADTRAN. When determining the alternate mounting location, ensure supplied cabling reaches the designated termination point including dressing and lacing.

Provisioning

Aside from various PS/BC and battery mounting and wiring configurations, there are no end user controls, adjustments, or options associated with the PS/BC.

WIRING DESCRIPTIONS

The wiring required for the single PS/BC and dual battery configuration is included.

CAUTION

All grounds must terminate at a known ground location. Check metal-to-metal contact on all ground connections. Do not stack or combine grounds. Ensure ground circuit continuity.

Ground

A ground post adjacent to the PS/BC fuse is available for frame ground.

WARNING

Do not connect AC power or make battery connections until all other connections have been made for the designated installation and protective covers and shields have been installed.

120 VAC Power Input

AC input is through a 10-foot wire with a three prong grounded plug on the end. The line is hardwired to the PS/BC.

NOTE

In the optional two PS/BC configuration, a fully redundant system requires that each PS/BC have an independent AC source.

DC Power Output

The 4-foot long, three conductor PS/BC power output wire originates at the **-54V 6A OUTPUT** modular connector and terminates at three #6 ring lugs for customer designated connection. Wire color-code is as follows:

- Red = -54 VDC
- Black = Return
- Green = Ground

PS/BC to Battery Configurations

The basic design configuration consists of one PS/BC with two batteries. A variety of other configurations are possible with more (or less) redundant capability, see **Figure 3** for standard configurations I and II.

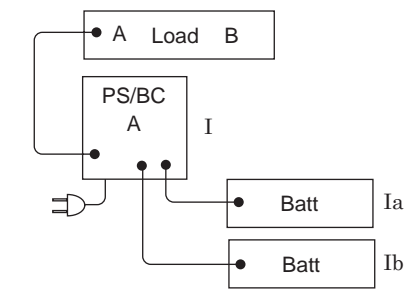

- Configuration I, Ia, Ib
 I. PS/BC, no battery.
 Ia. PS/BC + 1 battery string.
 Ib. PS/BC + 2 battery strings.

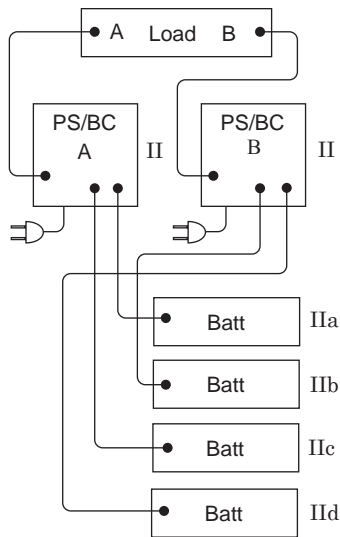

- Configuration II, IIa, IIb, IIc, IId
 II. 2 PS/BC, no battery.
 IIa. 2 PS/BC + 1 battery string.
 IIb. 2 PS/BC + 2 battery strings.
 IIc. 2 PS/BC + 3 battery strings.
 IId. 2 PS/BC + 4 battery strings.

This configuration shows adding battery strings alternately to PS/BC A and B. Other wiring configurations are optional.

Figure 3. Wiring Block Diagrams

These would include one or two PS/BCs, none, one, or two batteries, or some combination of PS/BC and battery. The most reliable configuration would be two PS/BCs with two batteries each and with independent AC sources. The two PS/BC outputs would terminate at a single load that has primary and secondary power sharing terminals.

Battery Charge/Discharge

CAUTION

To prevent battery discharge prior to system operation, do not connect the battery to the PS/BC until the AC power is connected or imminent.

Each battery has a hardwired 6-foot battery charge/discharge wire that originates at the battery housing and terminates at a modular connector. The PS/BC has two mating connector ports each labeled **-48V 3A INPUT**. It does not matter which battery connects to which port.

To prevent heat buildup the battery charge current is limited to 1 amp per battery. This eliminates the need for temperature compensation.

Alarm Wiring

The alarm relay output originates at a modular connector with a 6-foot wire stub. Wiring termination of the output is customer designated. The alarm outputs: AC Fail, Battery Low Voltage, are assigned the following wire color-codes:

- ACF = orange, orange/white
- BV = blue, blue/white

OPERATION

The PS/BC starts operation when AC or battery power is applied. During operation ambient temperature can increase up to 50°C without affecting output. If ambient temperature increases beyond 50°C, output must be derated. At 70°C ambient, output load is limited to 5 amps.

CAUTION

External PS/BC surfaces can become hot during operation above 50°C ambient temperature.

MAINTENANCE

The Total Access PS/BC does not require routine maintenance for normal operation.

ADTRAN does not recommend that repairs be attempted in the field. Repair services may be obtained by returning the defective unit to ADTRAN. Refer to [“Appendix A, Warranty”](#) for further information.

Fuse

If the fuse fails, replace with a fuse of identical type and rating.

SPECIFICATIONS

Power Factor specifications for the Total Access PS/BC are listed in [Table 2](#). PS/BC specifications are listed in [Table 3](#).

Table 2. Power Factor and Efficiency

Power Output vs. Efficiency			
Power Output	Power Factor	Efficiency	Power Dissipation
50 watts	> 98%	> 81%	11 watts
150 watts	> 99%	> 89%	18 watts
325 watts	> 99%	> 91%	29 watts

Table 3. PS/BC Specifications

Specification	Description
Environmental	
Operating Temperature:	-40°C to 50°C
Derated Operation, Linear:	50°C to 70°C (0.05 amp/°C)
Storage Temperature:	-40°C to 85°C
Relative Humidity:	95 percent noncondensing
Max Heat Dissipation:	29 watts at 325 watts output 50 watts maximum during overload
Physical	
Height:	3.45 inches
Width:	15.35 inches (with mounting tabs)
Depth:	2.92 inches
Weight:	5.5 pounds
Electrical	
AC Input:	120 Volts, 3.75 amps max, 60 Hz
DC Output:	-54 Volts, 6 amps
Max power up to 50°C:	6 amps
Max power @ 70°C:	5 amps
Power Output:	325 watts
Compliance	
NEBS:	Level 3+
UL:	60950
ETL:	Listed
FCC:	Part 15, Class A

Appendix A

Warranty

WARRANTY AND CUSTOMER SERVICE

ADTRAN will replace or repair this product within the warranty period if it does not meet its published specifications or fails while in service. Warranty information can be found at www.adtran.com/warranty.

Refer to the following subsections for sales, support, Customer and Product Service (CAPS) requests, or further information.

ADTRAN Sales

Pricing/Availability:

800-827-0807

ADTRAN Technical Support

Pre-Sales Applications/Post-Sales Technical Assistance:

800-726-8663

Standard hours: Monday - Friday, 7 a.m. - 7 p.m. CST

Emergency hours: 7 days/week, 24 hours/day

ADTRAN Repair/CAPS

Return for Repair/Upgrade:

(256) 963-8722

Repair and Return Address

Contact CAPS prior to returning equipment to ADTRAN.

ADTRAN, Inc.

CAPS Department

901 Explorer Boulevard

Huntsville, Alabama 35806-2807



Carrier Networks Division
901 Explorer Blvd.
Huntsville, AL 35806